

The information contained in this documentation is the property of MAZeT. Photocopying or otherwise reproducing any part of the catalog, whether electronically or mechanically, is prohibited, except where the express permission of MAZeT GmbH has been obtained. In general, all company and brand names, as well as the names of individual products, are protected by brand, patent or product law.

REVISIONS

REV:	DISCRIPTION	APPROVED
1	V 1.8	2007-08-01

DATA-SHEET

MCSiAT/BT

Integral 3-Element Color Sensor

Table of Contents

1. FUNCTION	2
2. APPLICATION	2
3. FEATURES	2
4. CONSTRUCTION	2
5. MAXIMUM RATINGS / CHARACTERISTICS	3
6. CHARACTERISTIC CURVE	4
7. PACKAGE OVERVIEW	5
8. PIN-CONFIGURATION	6
9. APPLICATION CIRCUIT	6
10. APPLICATION NOTE	6
11. ORDERING INFORMATION	7

MAZeT GmbH Sales
 Göschwitzer Straße 32
 07745 JENA / GERMANY
 Phone: +49 3641 2809-0
 Fax: +49 3641 2809-12
 E-Mail: sales@MAZeT.de
 Url: <http://www.MAZeT.de>

Approvals	Date
Compiled:	2007-08-01
Checked:	2007-08-01
Released:	2007-08-01

MAZeT GmbH

Status: valid

DOC. NO: DB-99-070e

Page 1 of 7

REV.	DESCRIPTION	APPROVED
1	V 1.8	2007-08-01

1. FUNCTION

The color sensors are made of 19 x 3 Si-PIN photo diodes integrated on chip. They are carried out as a hexagonal matrix with the diameter of 3 mm. The design as Si-PIN photo diodes allows signal frequencies up to MHz-range. In order to achieve a small cross talk between the photodiodes the individual sectors have been separated from each other by additional structures. Each of these photodiodes is sensitized with dielectric spectral filter for its color range, preferably for the primary colors red, green and blue.

2. APPLICATION

- Quality control
- Monitoring the production
- Control of manufacturing
- Detection of color marks

3. FEATURES

Dielectric filters guarantee the good optical properties of the color sensors, such as:

- high transmission
- slight aging of the filter
- high temperature stability
- high signal frequency
- reduced cross talk
- small size (diameter of the optical sensitive surface ca. 3 mm)
- insensitiveness to decentralized imaging, e. g. LWL coupling
- ROHS conform



4. CONSTRUCTION

- 3 x 19 on chip integrated PIN photo diodes
- dielectric filters for the three color ranges: red, green and blue
- different package versions (TO5 with/without IR-blocking)
- Electrical connections
 - three anodes
 - one common cathode



REV.	DESCRIPTION	APPROVED
1	V 1.8	2007-08-01

5. MAXIMUM RATINGS / CHARACTERISTICS

(TA = 25°C; per single diode)

Description	Symbol	Condition	typ. Value	Unit
Diameter of the light sensitivity area	D		3,0	mm
Light sensitivity area per element	A		0,06	mm ²
Photo sensitivity of color ranges	S _{max}	$\lambda_B = 470 \text{ nm}$ $\lambda_G = 570 \text{ nm}$ $\lambda_R = 650 \text{ nm}$	0,26 0,33 (0,25) 0,41	A/W
Photo sensitivity per color	A		1,2	mm ²
Field of the spectral sensitivity $\pm 2\% \cdot \lambda$	λ_B λ_G λ_R		400 - 510 490 - 610 590 - 750	nm
Rise and fall time of the photocurrent	t _r , t _f		<1	μs
Noise equivalent power	NEP		<10 ⁻¹³	W/ $\sqrt{\text{Hz}}$
Crosstalk			5	%
Angle of incidence	φ	$\Delta\lambda_{(\text{Filter})} < 1\% \cdot \lambda$	8	Grad
Operating temperature range	T _{op}		0 ... +70	°C
Storage temperature range	T _{st}		-20 ... +80	°C
Soldering temperature	T	2...3 sec	240	°C
Reference voltage (see also chapter 9 Application Circuit)	VREF		0,4 ... VDD-0,4	V

REVISIONS		
REV.	DESCRIPTION	APPROVED
1	V 1.8	2007-08-01

6. CHARACTERISTIC CURVE

6.1 Typical spectral sensitivity of the integral color sensor without IR-blocking¹

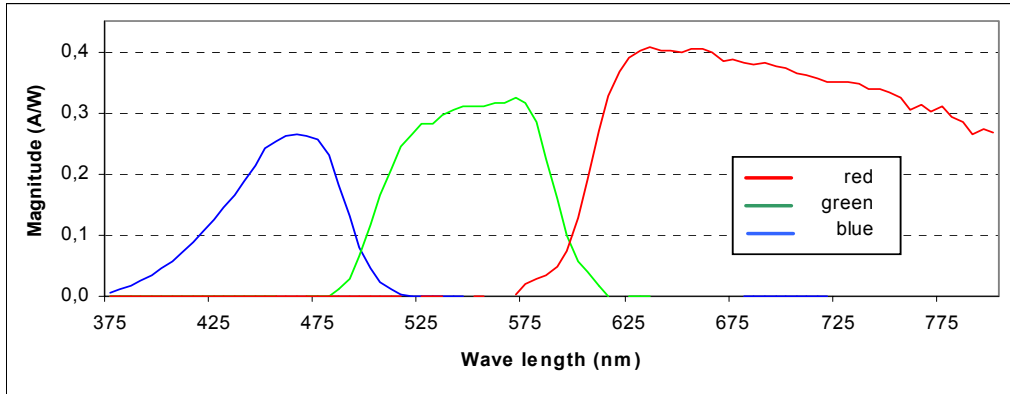

6.2 Typical spectral sensitivity of the integral color sensor with IR-blocking¹

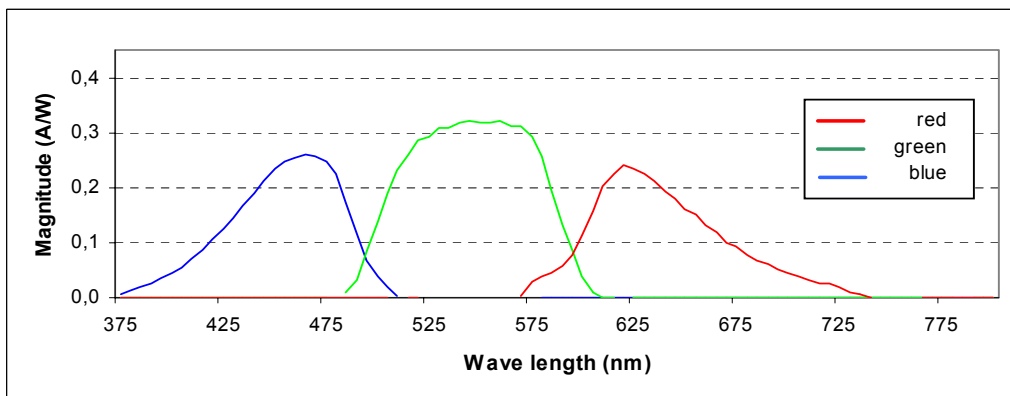

¹ Typical characteristic sensitivity; scanned by monochromatic light with FWHM 27nm, not suitable for narrow light, e.g. laser

REVISIONS		
REV.	DESCRIPTION	APPROVED
1	V 1.8	2007-08-01

7. PACKAGE OVERVIEW

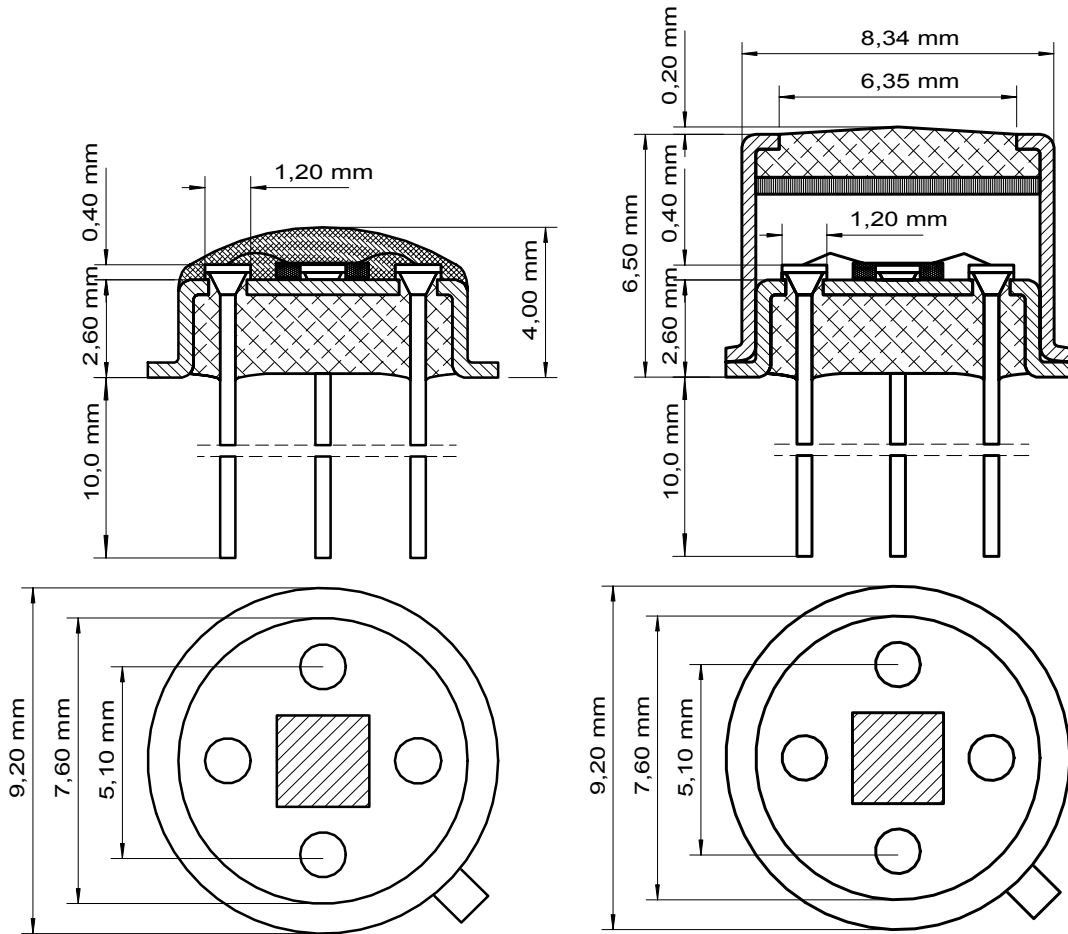

TO5 with transp. encapsulation (MCSiAT)

TO5 with window cap/
IR-blocked (MCSiBT)

REV.	DESCRIPTION	APPROVED
1	V 1.8	2007-08-01

8. PIN-CONFIGURATION

(Top view)

PIN-	description
A1	red
A2	blue
A3	green
A4	common cathode

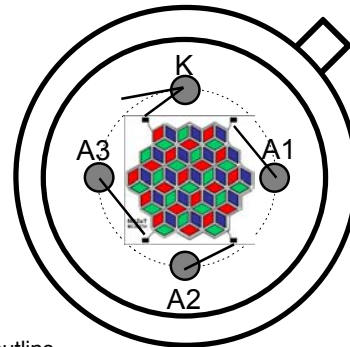

TO5-outline

9. APPLICATION CIRCUIT

Opposite figure shows a circuit for the conversion of photo current to an equivalent voltage. These voltage can be processed e.g. with an ADC. By the selection of suitable resistors the output voltage range can be adjusted to the photo current value. (for example the pin-programmable transimpedance amplifier MAZeT MT104 with the resistors 25kΩ, 500kΩ and 5MΩ)

$$R_x \approx \frac{V_{Out}}{I_{Photo}}$$

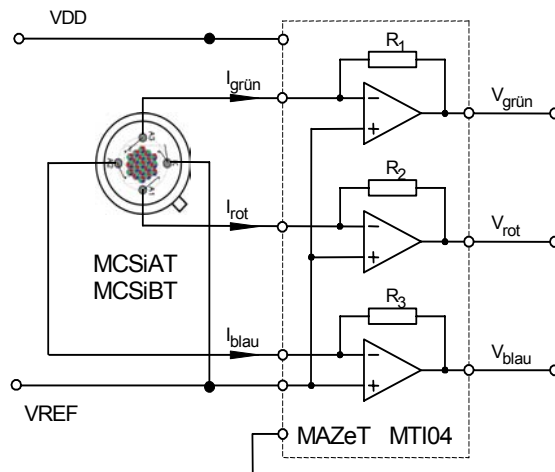

10. APPLICATION NOTE

It is recommended to use an IR-block filter > 720nm or a light source with low infrared radiation for optimal operations of the color sensor.

REVISIONS

REV.	DESCRIPTION	APPROVED
1	V 1.8	2007-08-01

11. ORDERING INFORMATION

Integral color sensor MCSi with TO5-package + transparent encapsulation	MCSiAT
Integral color sensor MCSi with TO5-package + glass cap IR-blocked	MCSiBT
Evaluation board for JENCOLOR sensors	MCS-EB1

For further information please contact:

MAZeT GmbH**Sales office:**

Göschwitzer Straße 32

07745 JENA

GERMANY

Phone: +49 3641 2809-0

Fax: +49 3641 2809-12

E-Mail: sales@MAZeT.de

Url: <http://www.MAZeT.de>**WARNINGS**

Personal Injury – Do not use these products as safety or emergency stop devices, or in any other applications where failure of the product could result in personal injury. **Failure to comply with these instructions could result in death or serious injury.**

Misuse of Documentation – The information presented in this data sheet is for reference only. Because this products are under development do not use this document as product installation guide. Before you start any development ask your supplier for the latest version of this sheet. **Failure to comply with these instructions could result in death or serious injury.**