

The information contained in this documentation is the property of MAZeT. Photocopying or otherwise reproducing any part of the catalog, whether electronically or mechanically, is prohibited, except where the express permission of MAZeT GmbH has been obtained. In general, all company and brand names, as well as the names of individual products, are protected by brand, patent or product law.

REVISIONS

NO	VERSION	APPROVED
1	V 2.3	2007-08-01

Data Sheet

MTI04Bx-BF

**MULTI-CHANNEL PROGRAMMABLE GAIN
TRANSIMPEDANCE AMPLIFIER**

Table of contents

1. GENERAL DESCRIPTION	2
2. BLOCK DIAGRAM	2
3. DESCRIPTION OF INTERFACE	3
3.1 Pinning	3
3.2 Adjustment Of Transimpedance	3
4. DESCRIPTION OF FUNCTION	3
5. ELECTRICAL CHARACTERISTICS	4
5.1 Maximum Conditions	4
5.2 Operating Conditions	4
5.3 AC/DC-Characteristics	4
5.3.1 Offset Voltage At Input INX	5
5.3.2 Leakage Current At Input INX	6
5.3.3 DC-Transfer-Curves	7
6. PACKAGES	8
6.1 Shape and Dimensions	8
6.2 Pin-Configuration	10
7. APPLICATIONS	10
7.1 Example For Position Measurement	10
7.2 Connection Of A Color Sensor	11
8. ORDERING INFORMATION	12
9. CONTACT	12

MAZeT GmbH Sales
 Göschwitzer Straße 32
 07745 JENA / GERMANY
 Phone: +49 3641 2809-0
 Fax: +49 3641 2809-12
 E-Mail: sales@MAZeT.de
 Url: http://www.MAZeT.de

Approvals	Date
Compiled:	2007-08-01
Checked:	2007-08-01
Released:	2007-08-01

MAZeT GmbH	
Status: valid	
DOC. NO: DB-99-072e	Page 1 of 12

NO	VERSION	APPROVED
1	V 2.3	2007-08-01

1. GENERAL DESCRIPTION

The MTI-devices are a family of integrated circuits of **programmable gain transimpedance amplifiers** with **different numbers of channels** (4 standard, others custom specific).

The MTI-devices are mainly used for **signal conditioning of sensors with current outputs**. They are especially suitable for connection of photodiodes of **array and row sensors**.

The possibility to **adjust the transimpedance in 3 stages** is a special feature. The adjustment is made by programming two pins and is valid for all channels together.

The device packages are optimized for **COB-mounting**.

2. BLOCK DIAGRAM

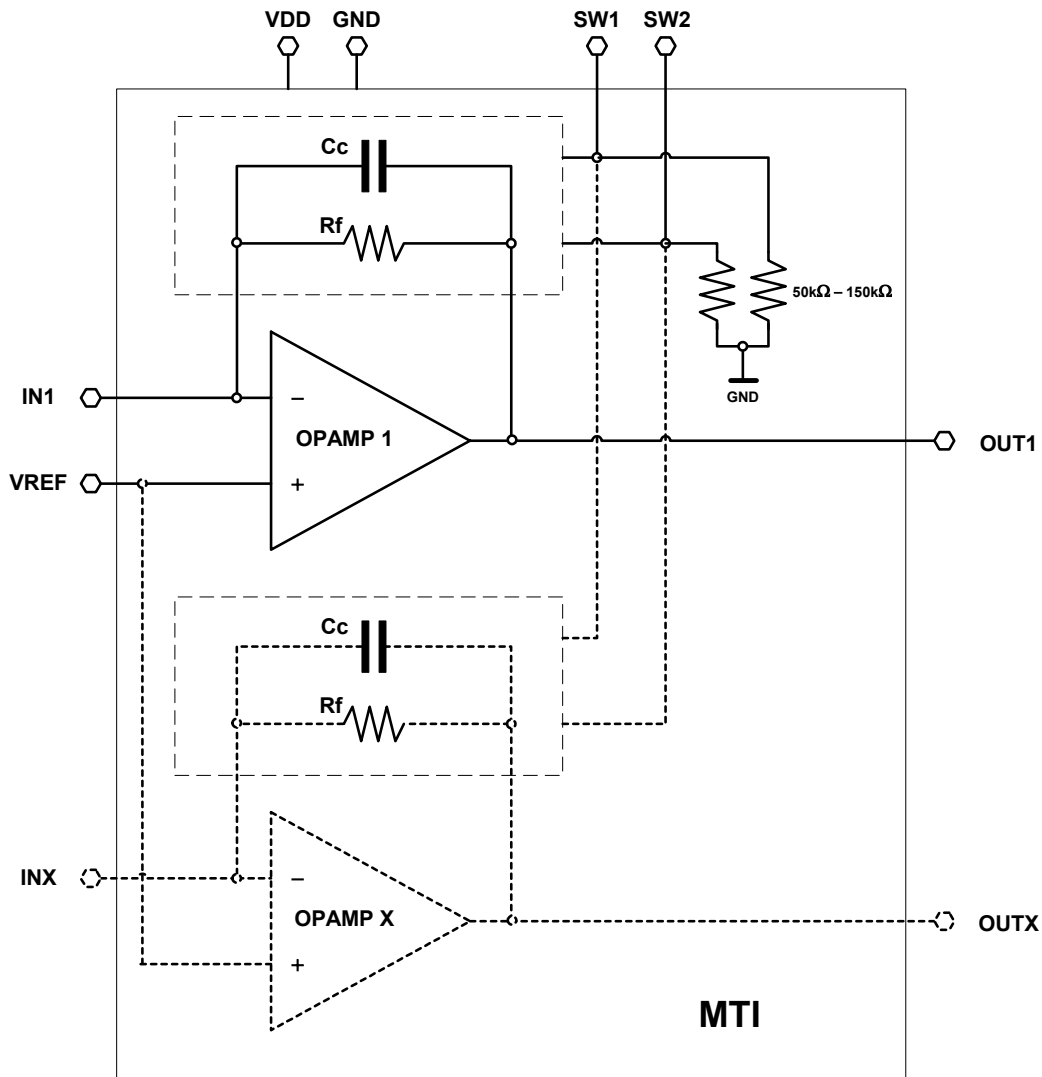

NO	VERSION	APPROVED
1	V 2.3	2007-08-01

3. DESCRIPTION OF INTERFACE

3.1 Pinning

signal name	Typ.	a/d ^a	function
VDD	input	a/d	power supply
GND	input	a/d	power supply
SW1	input	d	input 1 for adjustment of transimpedance of MTI-amplifier (pull down)
SW2	input	d	input 2 for adjustment of transimpedance of MTI-amplifier (pull down)
INX	input	a	analog current input of amplifier X
OUTX	output	a	analog voltage output of amplifier X

a.) analog or digital

3.2 Adjustment Of Transimpedance

settings of digital inputs		transimpedance R _f
SW1	SW2	
GND	VDD	5M Ω – stage 1
VDD	GND	500k Ω – stage 2
GND	GND	25k Ω ^a – stage 3
VDD	VDD	not used

a.) default by pull down

4. DESCRIPTION OF FUNCTION

The MTI-devices are programmable gain transimpedance amplifiers with different numbers of channels (MTI04 – 4 channels). There is one transimpedance amplifier per channel between a current input INX and a voltage output OUTX. Its transimpedance is selectable in 3 stages. This adjustment can be effected by setting of digital inputs SW1 and SW2 and is valid for all channels simultaneously (headline 3.2). The inputs SW1 and SW2 are pulled down with a resistor for a default feedback resistor of 25k.

The second input of all transimpedance amplifiers is used for a *common* supply by a reference voltage necessarily fed in through the pin VREF.

All channels are compensated for an external input capacitance of the photo-sensor of typical 20pF.

The power supply for the MTI-devices is typical 5V between VDD and GND.

NO	VERSION	APPROVED
1	V 2.3	2007-08-01

5. ELECTRICAL CHARACTERISTICS

5.1 Maximum Conditions

Violations of absolute maximum conditions are not allowed under any circumstances, otherwise the IC can be destroyed. All voltages are referenced to VSS = 0V.

parameter	name	min.	max.	unit
power supply	VDD	0.3	7.0	V
input and output voltages	⇒ IC-pinning	0.3	VDD 0.3	V
power dissipation	P _{OP}		0.1	W
operating temperature	T _{OP}		85	°C
storage temperature	T _{STG}	55	155	°C

5.2 Operating Conditions

All voltages are referenced to VSS = 0V.

parameter	name	min.	typ.	max.	unit	condition
supply voltage	VDD	4.5	5	5.5	V	
Bias current MTI04	I(VDD)	3		4	mA	27°C
operating temperature	T _{OP}		27	85	°C	
input high level	V _{IH}	2.0		VDD+0.3	V	
input low level	V _{IL}	0.3		0.8	V	
reference voltage	VREF	1	2.5	4	V	

5.3 AC/DC-Characteristics

Unless otherwise specified the data in this table is valid for T_{OP} = 27°C and VDD = 5V.

parameter	name	min.	typ.	max.	unit	condition
input current	INX		0,1		μA	stage 1
			1		μA	stage 2
			20		μA	stage 3
feedback resistor	Rf	4000	5000	6000	kΩ	stage 1
		400	500	600	kΩ	stage 2
		20	25	30	kΩ	stage 3
signal frequency at input	f _{3dB}		25		kHz	stage 1
			70		kHz	stage 2
			500		kHz	stage 3
temperature coefficient of the feedback resistor	TC _{Rf}		3500		ppm/K	
input offset voltage	V _{OFF}			8	mV	T _{OP} = 85°C
input leakage current	I _{LEAK}			500	pA	T _{OP} = 85°C
capacitive load at OUTX	C _{LOAD}			50	pF	I _{LOAD} = 0,5mA
pull down resistor at SW1 and SW2	R _{PDSW}	50			k	
input capacitance of external connected photo-sensors	C _{DIODE}		20		pF	per input

NO	VERSION	APPROVED
1	V 2.3	2007-08-01

5.3.1 Offset Voltage At Input INX

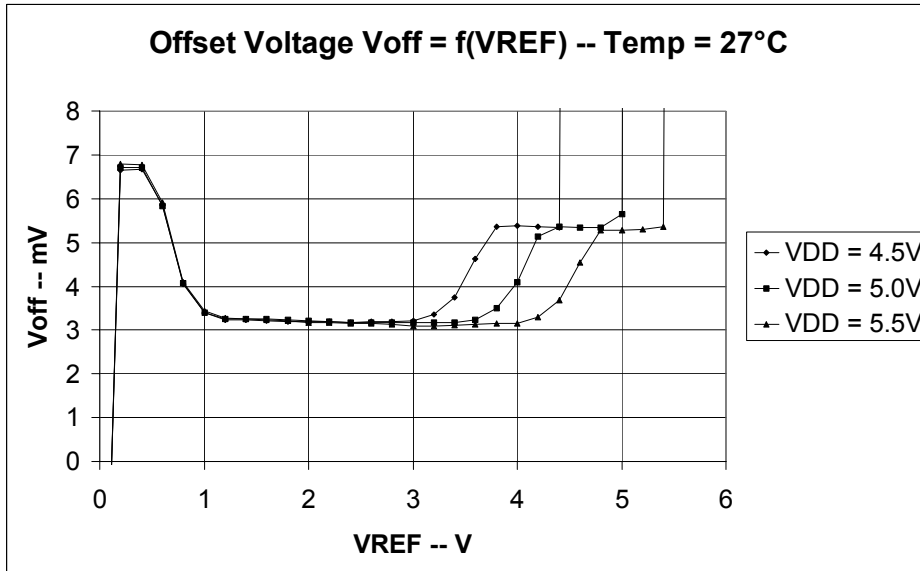
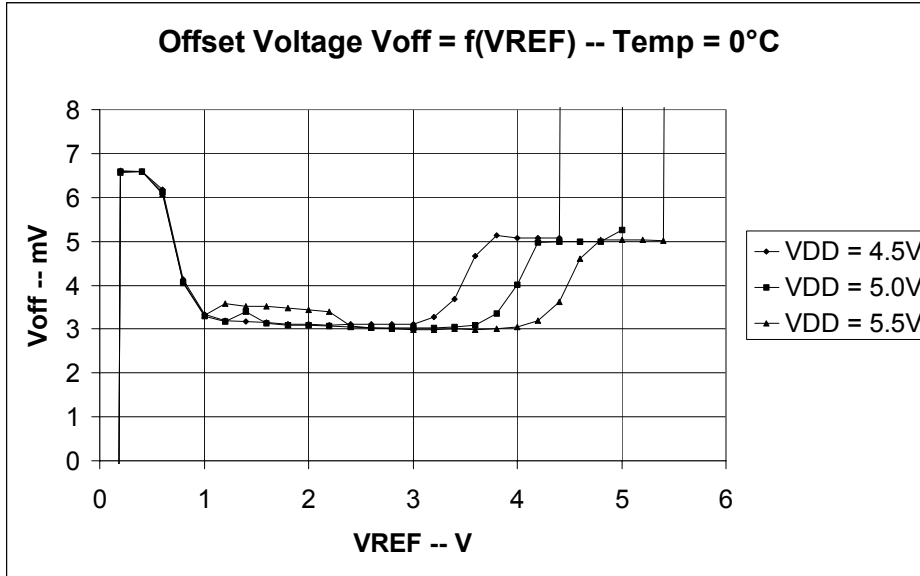

NO	VERSION	APPROVED
1	V 2.3	2007-08-01

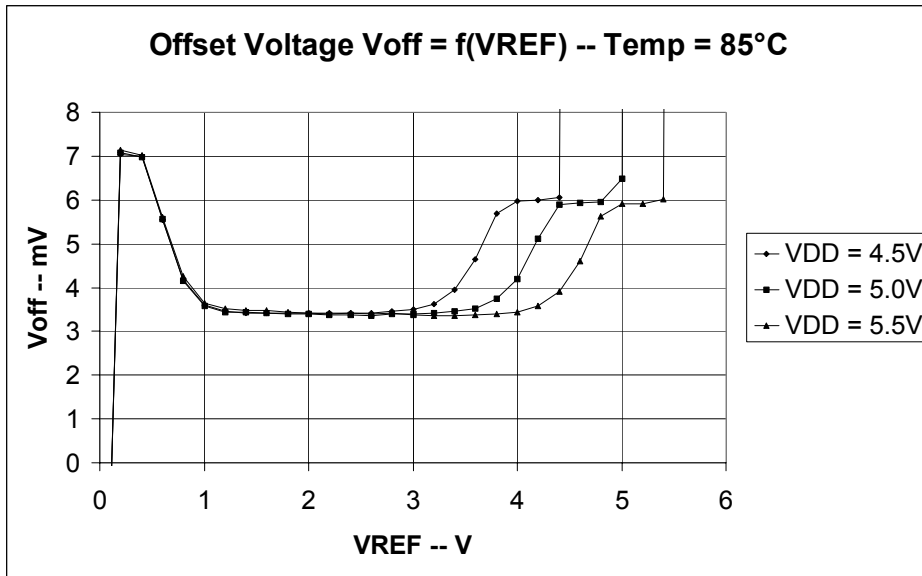

5.3.2 Leakage Current At Input INX

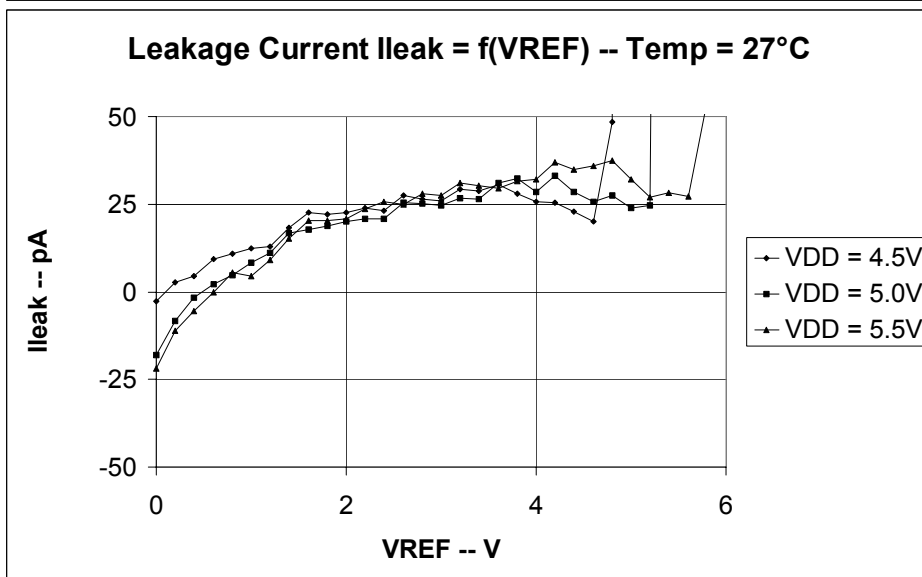
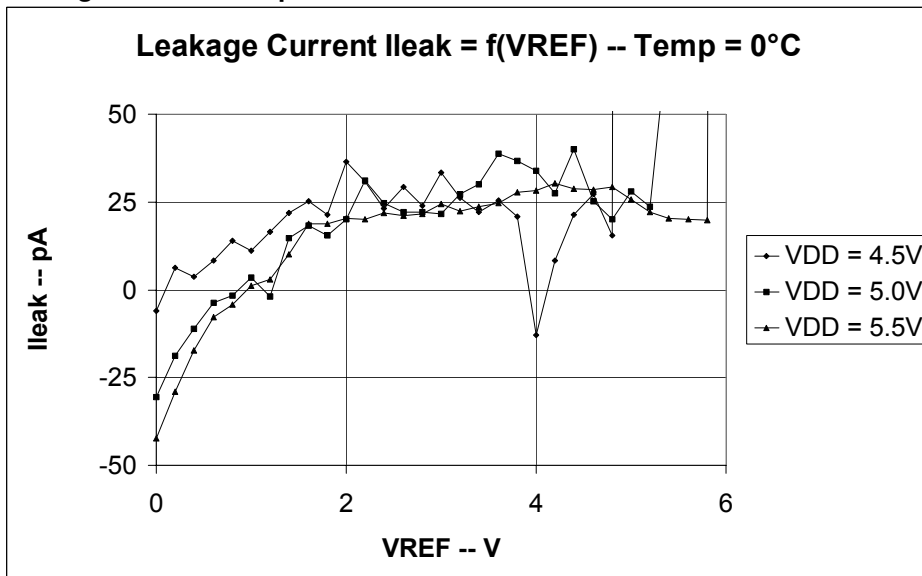

NO	VERSION	APPROVED
1	V 2.3	2007-08-01

Leakage Current $I_{leak} = f(V_{REF})$ -- Temp = 85°C

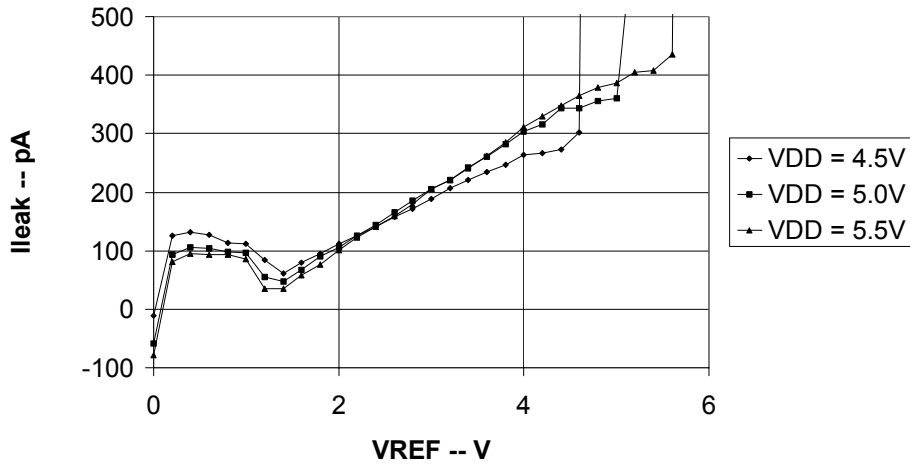

5.3.3 DC-Transfer-Curves

DC-Transfer-Curve $V(OUTX) = f(I(INX))$ -- $R_f = 25k\Omega$

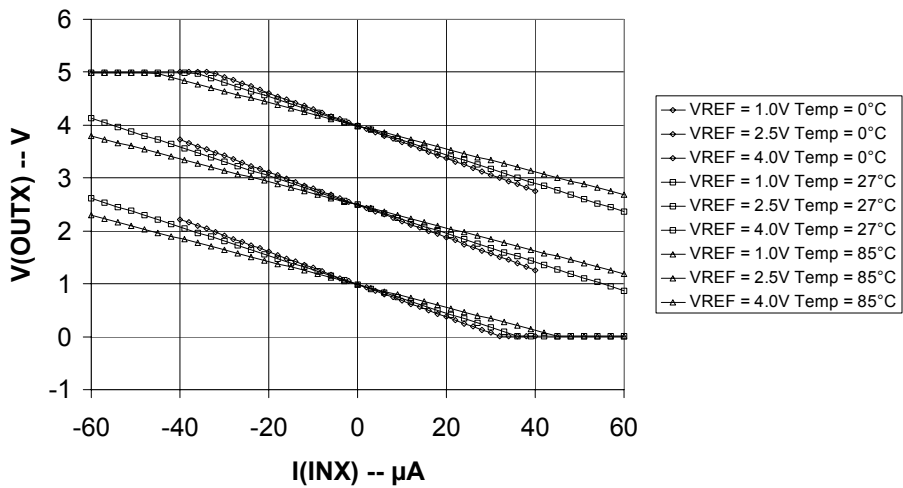

NO	VERSION	APPROVED
1	V 2.3	2007-08-01

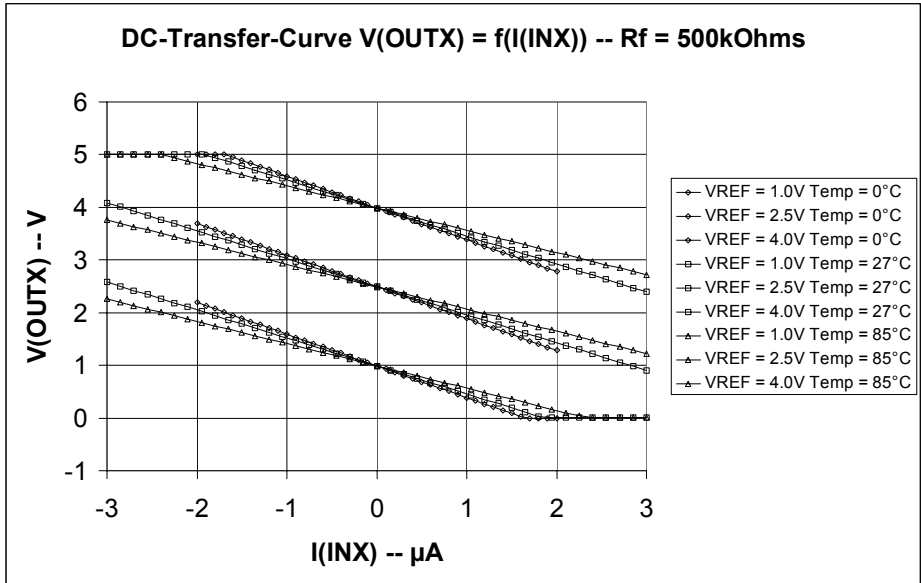

6. PACKAGES

6.1 Shape and Dimensions

tapered edge¹⁾

DATA SHEET MTI04Bx-BF

REVISIONS

NO	VERSION	APPROVED
1	V 2.3	2007-08-01

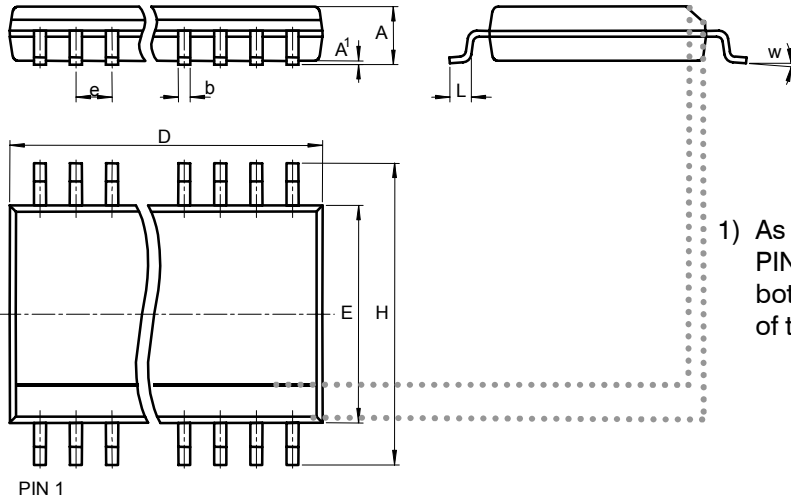

dimensions – mm

TYP	PACKAGE	D	E	H	A	A1	e	b	L	w
MTI04BS	SOP16	9.90	3.80	6.00	1.75	0.15	1.27	0.41	0.72	4°
MTI04BQ	QSOP16	4.90	3.80	6.00	1.75	0.15	0.635	0.38	0.72	4°

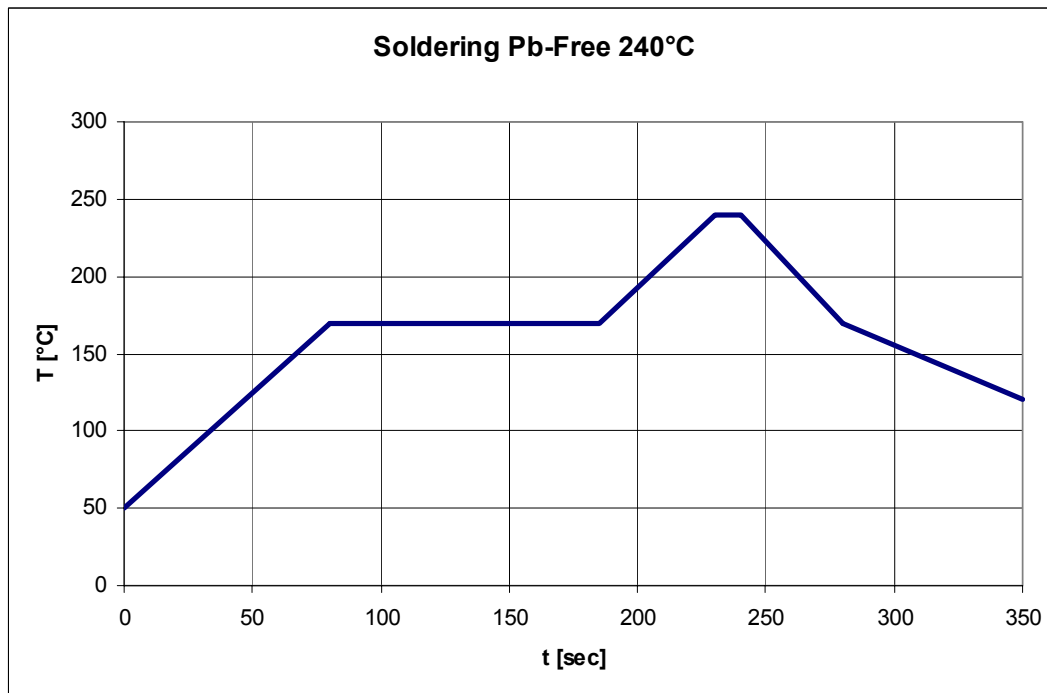

NO	VERSION	APPROVED
1	V 2.3	2007-08-01

6.2 Pin-Configuration

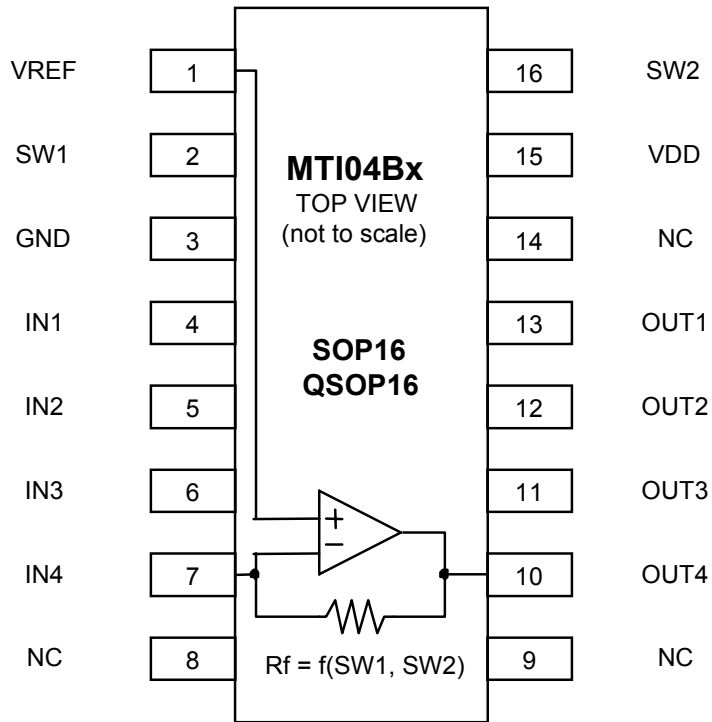

NNC = Not connected

7. APPLICATIONS

7.1 Example For Position Measurement

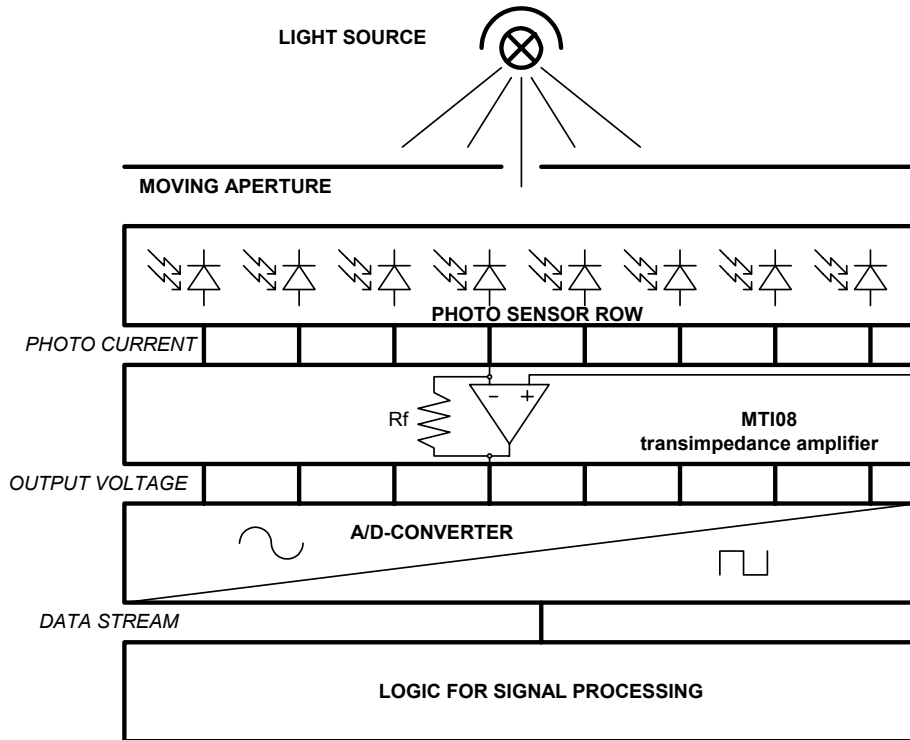

NO	VERSION	APPROVED
1	V 2.3	2007-08-01

7.2 Connection Of A Color Sensor

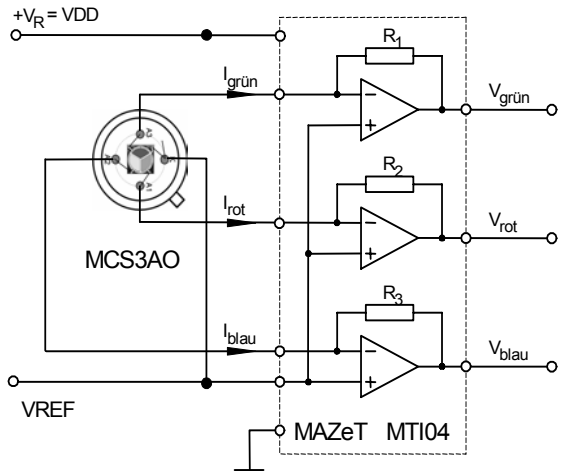
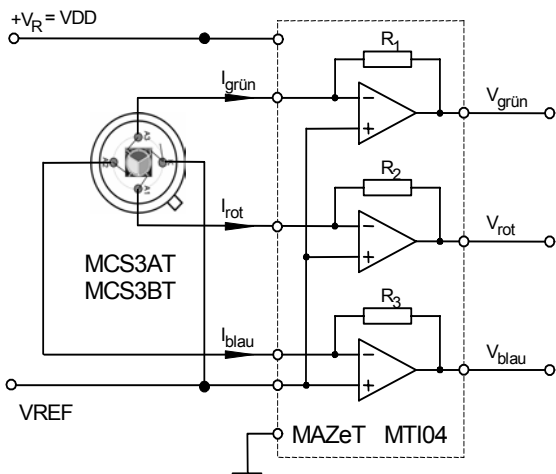
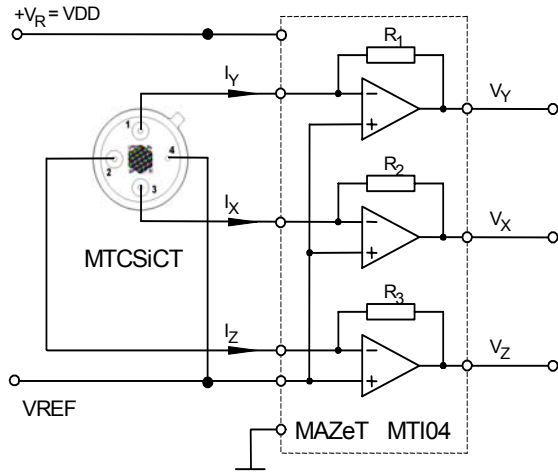
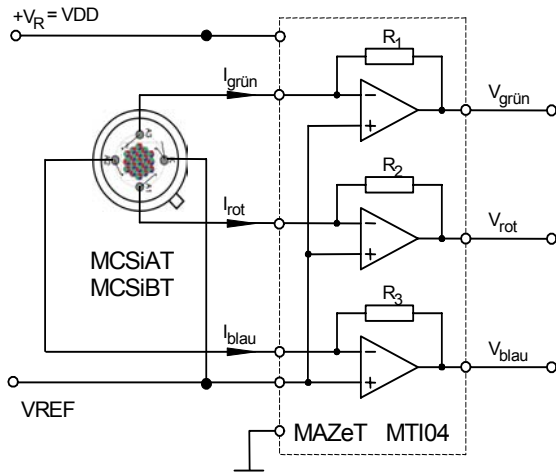
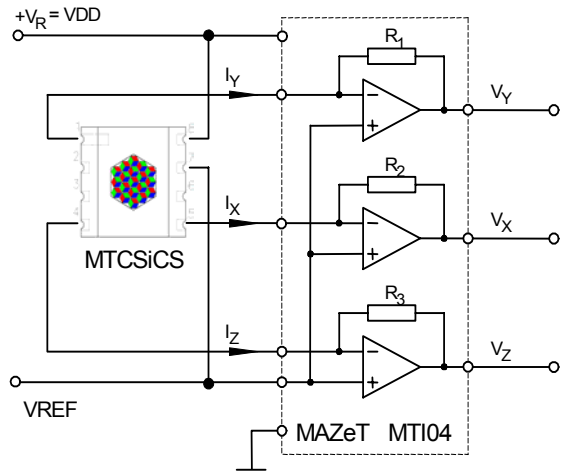
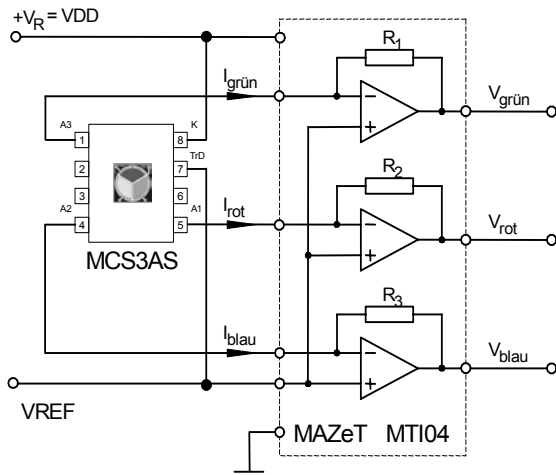

NO	VERSION	APPROVED
1	V 2.3	2007-08-01

8. ORDERING INFORMATION

NAME OF PRODUCT	PACKAGE	NUMBER OF CHANNELS
MTI04BS-BF	SOP16	4
MTI04BQ-BF	QSOP16	4

9. CONTACT

For further information, please feel free to contact:

MAZeT GmbH
Sales office:
Göschwitzer Straße 32
07745 JENA
GERMANY
Phone: +49 3641 2809-0
Fax: +49 3641 2809-12
E-Mail: sales@MAZeT.de
Url: <http://www.MAZeT.de>